

Fixing Guide

Continuous Dry Verge System

The Continuous Slate Dry Verge System is designed for use with most natural and man-made slates. The system for TapcoSlate Classic fits slate up to a maximum 6mm in thickness.

The Slate Dry Verge System is fitted to the top end of the battens and forms a fixing for the slate whilst covering the end of the battens.

Expansion joints are provided and the following instructions should be followed to avoid possible buckling or breaking during periods of hot or cold weather:

1. Trim ends of battens 2mm to 4mm from edge of barge board or brickwork and ensure they are securely fixed.
2. Fix first length of Dry Verge into position using suitable galvanised nails or outdoor screws as shown in Figure 1.
3. Make sure that the end of the gutter will fit in a suitable position for discharge, and if necessary, using a fine-toothed hacksaw, trim this end of the Dry Verge to fit as required.
4. Place the next section of Dry Verge into position by first sliding into position by first sliding into place a jointing clip and then attaching the second piece of Dry Verge to the jointing clip to form a bridge between the lengths. This jointing clip also continues the flow of water down the Dry Verge in line with BS5250 stipulations (as shown in Figure 2).
5. Continue fitting the Dry Verge up to the apex of the roof.
6. If a ridge tree or ridge batten is present, trim the Dry Verge using a fine-toothed hacksaw to leave a 10mm gap either side (as shown in Figure 4).
7. When fitting the slates into the Dry Ridge profile, care must be taken to avoid bending the profile too much with excessive force, and whilst the profile is extremely flexible, support should be provided to avoid breaking.

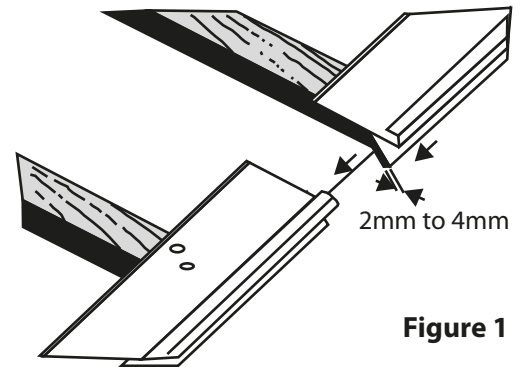

Figure 1

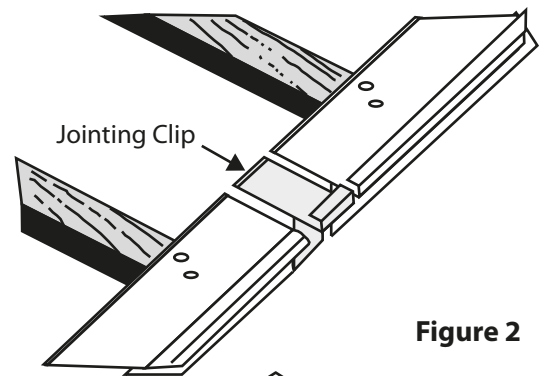

Figure 2

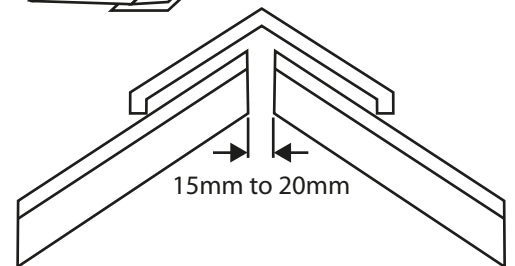

Figure 3

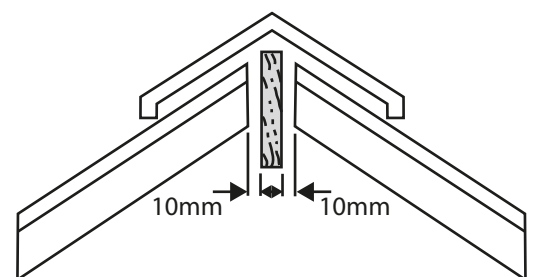

Figure 4

